

# E39/E26 LED Retrofit Kit

LED Retrofit kit is designed to meet the needs for indoor and outdoor lighting fixtures retrofit (both horizontal and vertical mount application), just replace the inside MH/ HPS lamp, the fixture remains.



### Horizontal



### Vertical



## Dimension

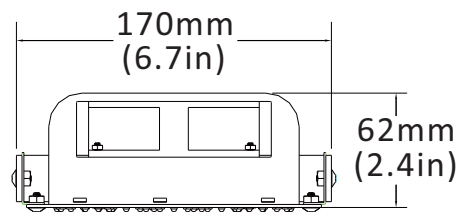
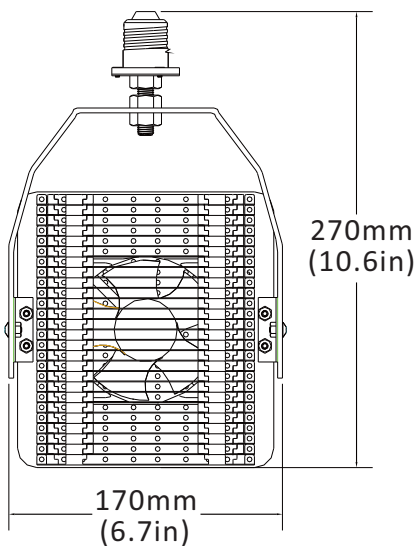

## Why us?

With 10 years experience, many clients have issues with other brand retrofit kits in the current market, most failures can be narrowed down to heat or driver problems. However, we are making the change to improve!

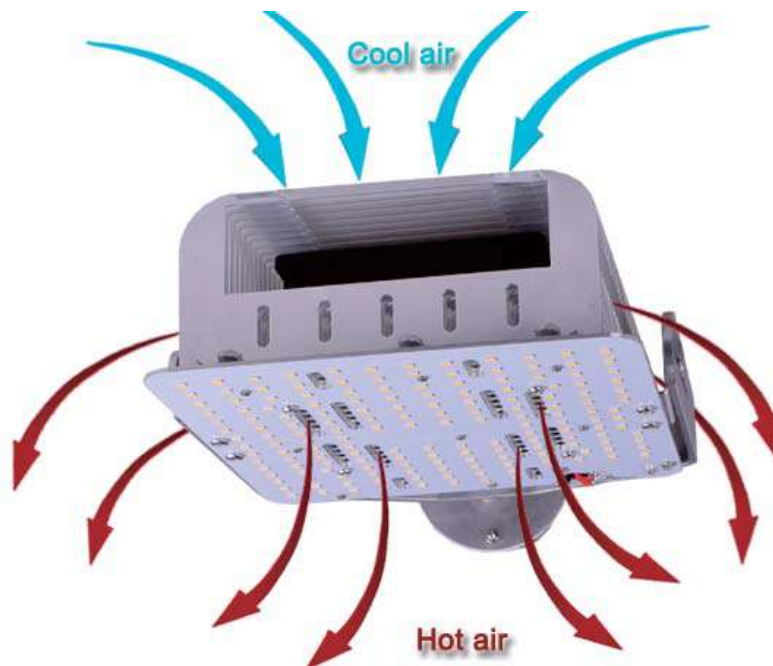

# Specification data

Item No.	Watts	Dimension	Luminous Flux (130lm/w)	Luminous Flux (150lm/w)	Replacement	CRI
<b>RFK-60W</b>	<b>60W</b>	<b>270*170*62mm</b>	<b>78,00lm</b>	<b>9,000lm</b>	<b>105-175w CFL, HID</b>	<b>Ra&gt;83</b>
<b>RFK-80W</b>	<b>80W</b>		<b>10,40lm</b>	<b>12,000lm</b>	<b>175-250w MH, HPS</b>	<b>Ra&gt;83</b>
<b>RFK-100W</b>	<b>100W</b>		<b>13,000lm</b>	<b>15,000lm</b>	<b>250-300w MH, HPS</b>	<b>Ra&gt;83</b>
<b>RFK-120W</b>	<b>120W</b>		<b>15,600lm</b>	<b>18,000lm</b>	<b>300-400w MH, HPS</b>	<b>Ra&gt;83</b>
<b>RFK-150W</b>	<b>150W</b>		<b>19,500lm</b>	<b>22,500lm</b>	<b>400-450w MH, HPS</b>	<b>Ra&gt;83</b>

- Standard 130lm/w or Optional 150lm/w
- Universal AC input 100-277Vac or 200-480Vac, PF>0.95
- Color temperature: 2700k, 3000k, 4000k, 4500k, 5000k, 5700k, 6000k, 6500k  
Amber, Red, Green, or Blue LED's.
- Life time: >50,000 hours
- Warranty: 5 years factory warranty

# Applications

This LED retrofit kit can be applied for all different shoebox fixtures, Cobra street fixtures, Wall pack fixtures that replace MH HPS HID lamp.  
(including enclosed applications)



# Projects



1. Turn off the Power.
2. Carefully remove the existing Lamp bulb.
3. Disconnecting the input and output leads of the Ballast, and remove the ballast. Please refer to below the schematic diagram.
4. Mounting the LED Driver in the same place as ballast, drilling the screws holes may apply.
5. Inset the retrofit kit to the E39 base, Adjust the retrofit head angle and position so that it provides the best lighting.
6. Connecting the Retrofit kit leads to the output leads of LED driver with suitable size of Marrette connectors, and then connecting the input leads of LED Driver to the supply wires with suitable size of Marrette connectors carefully.
7. Double check the Input and Output connection of LED Driver, and make sure all connections are correct and well connected.
8. Turn on the Power.

## Replace HPS/MH

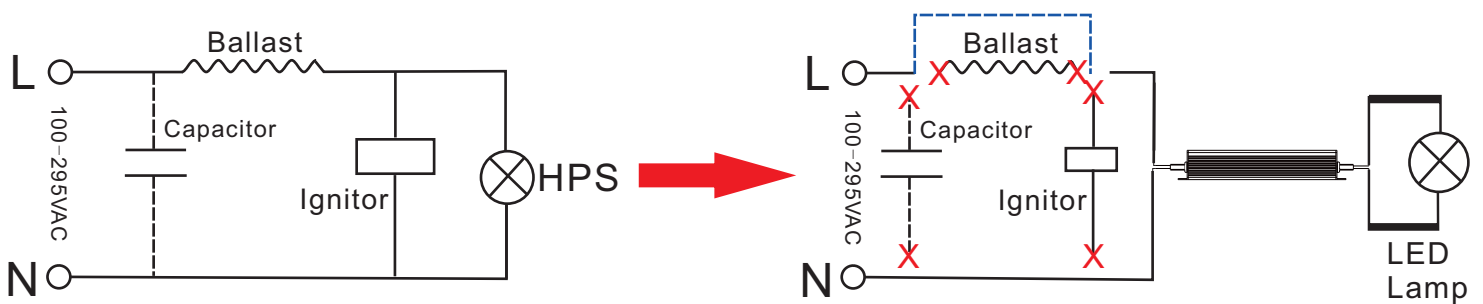

100-277VAC/  
200-480VAC

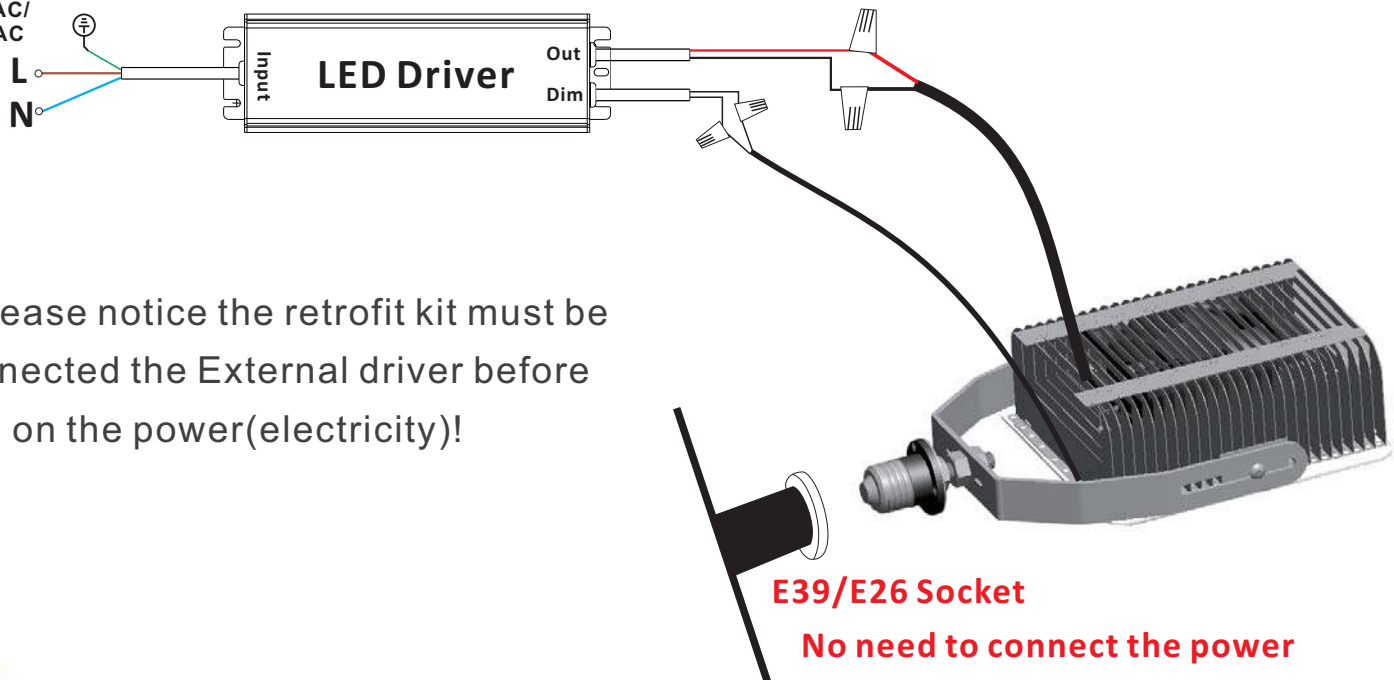

Please notice the retrofit kit must be connected the External driver before turn on the power(electricity)!



**Please remove any ballast or capacitor parts before doing the retrofit.**