

Installation Instruction

WARNING

- To reduce the risk of death, personal injury or property damage from fire, electric shock, falling parts, cuts/abrasions, and other hazards read all warnings and instructions included with and on the fixture box and all fixture labels.
- Before installing, servicing, or performing routine maintenance upon this equipment, follow these general precautions.
- Commercial installation, service and maintenance of luminaires should be performed by a qualified licensed electrician.
- For the installation: If you are unsure about the installation or maintenance of the luminaires, consult a qualified licensed electrician and check your local electrical code.
- To prevent wiring damage or abrasion, do not expose wiring to edges of sheet metal or other sharp objects.
- Do not make or alter any open holes in an enclosure of wiring or electrical components during kit installation.

WARNING

- Turn off electrical power at fuse or circuit breaker box before wiring fixture to the power supply.
- Turn off the power when you perform any maintenance.
- Verify that supply voltage is correct by comparing it with the luminaire label information.
- All wiring connections should be capped with UL approved wire connectors.

CAUTION

- Avoid direct eye exposure to the light source while it is on.
- Account for small parts and destroy packing material, as these may be hazardous to children.
- Risk of burn. Disconnect power and allow fixture to cool before changing bulb or handing fixture.

NOTICE: Green ground screw provided in proper location. Do not relocate.

NOTICE: Minimum 90°C supply conductors.

NOTICE: Specifications and dimensions subject to change without notice.

NOTICE: Suitable for Dry or Damp location

General Wiring Diagram

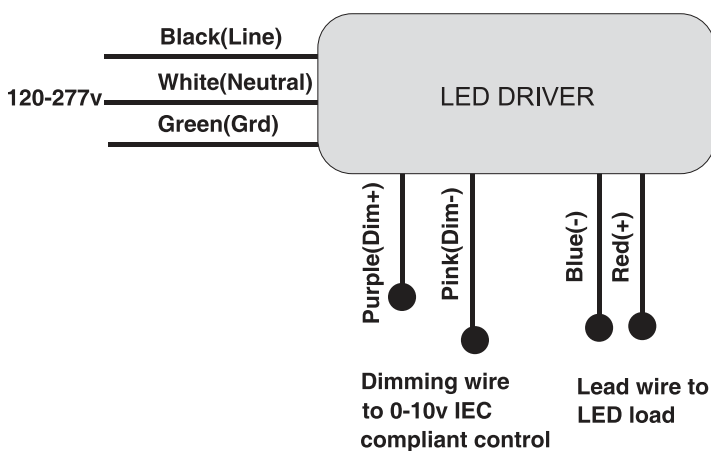

Installation Instruction

Surface Mounting :2FT

1. Take out the light fixture and accessories package from the box.

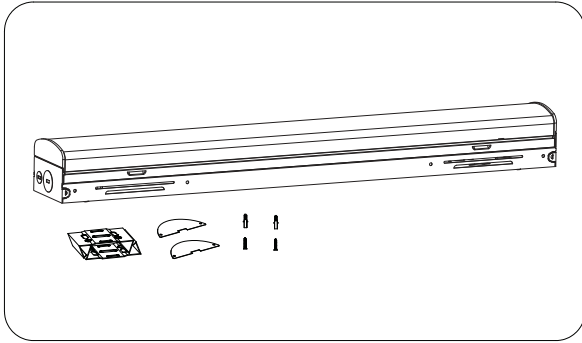

2. Secure the provided brackets onto the ceiling by using the provided accessories and screws.

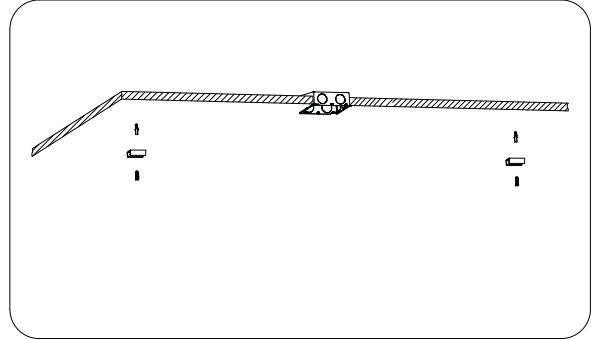

3. Fix the covers at the outlet of the back of the housing.

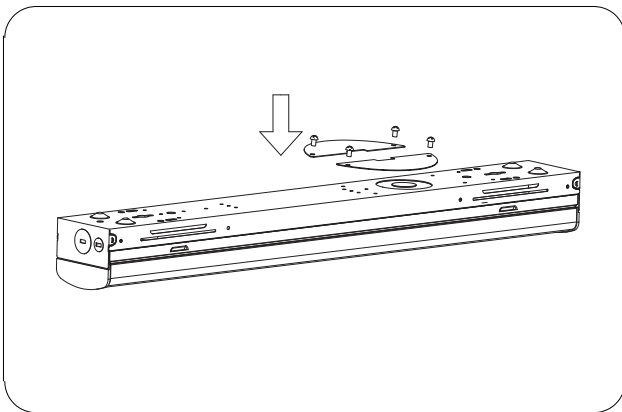

4. Wire to main power through the junction box.

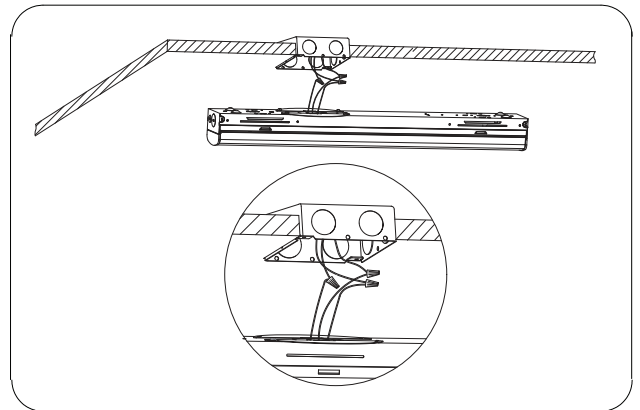

5. Clip the brackets to the slots of the fixture.
The installation is completed.

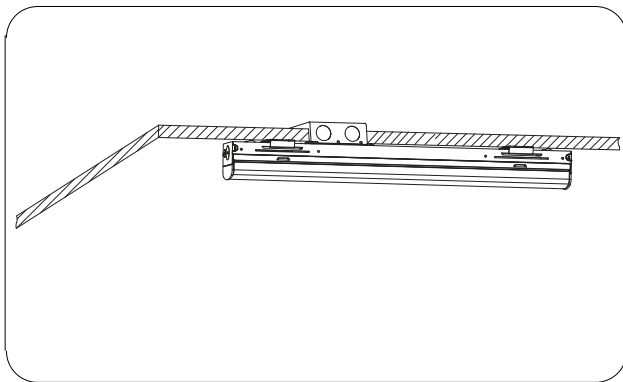

Installation Instruction

Surface Mounting :4FT&8FT

1. Take out the light fixture and accessories package from the box.

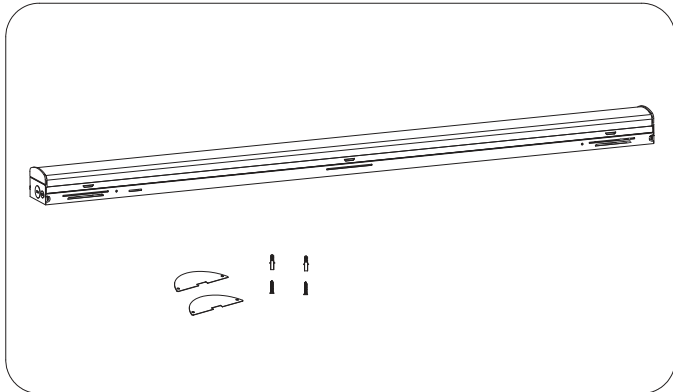

2. Fix the baffle on the lamp.

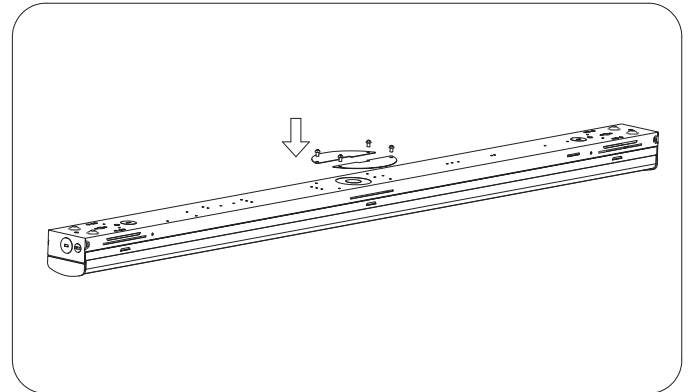

3. Open the module board down.

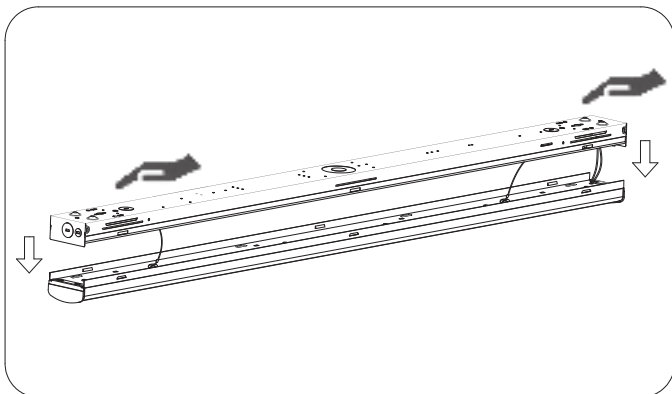

4. Fix the lamp to the ceiling with the plastic sleeve and screws provided.

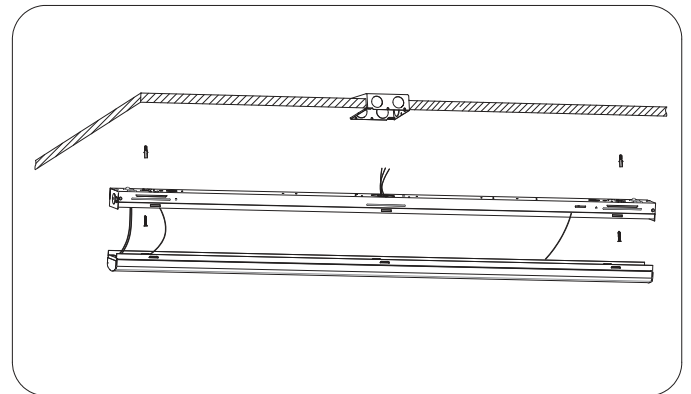

5. Wire to main power through the junction box.

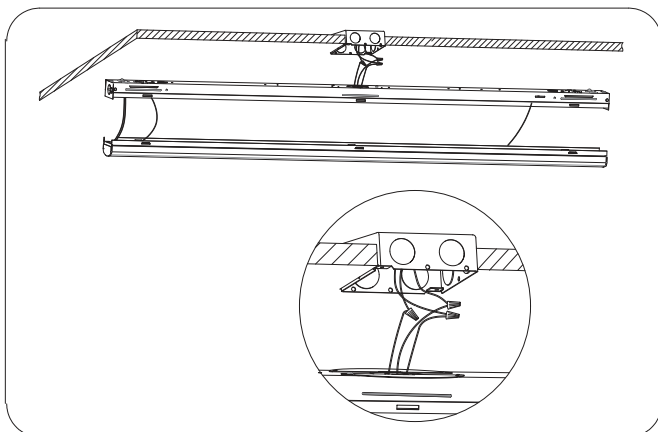

6. Assemble the module board upwards. The installation is completed.

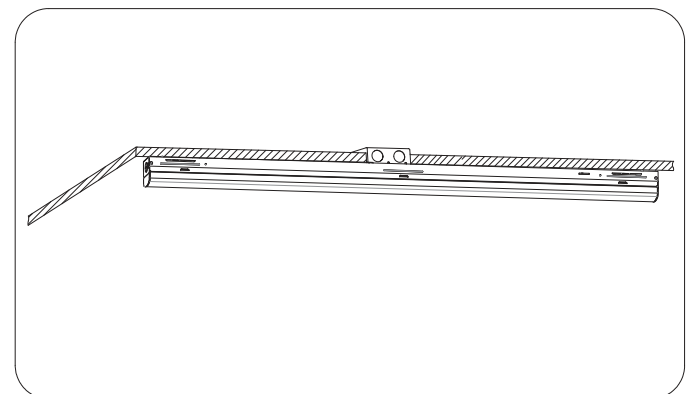

Installation Instruction

Cable Suspended Mounting

1. Take out the light fixture and accessories package from the box.

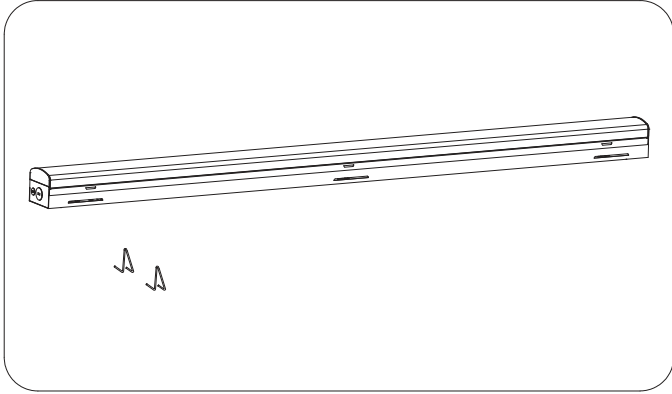

2. Attach V-hooks to the cable.

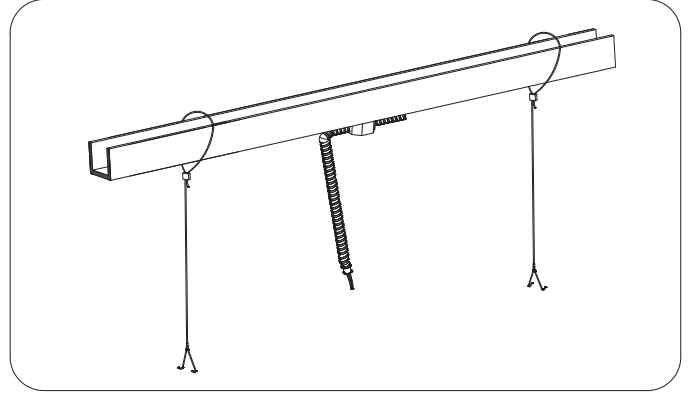

3. Connect the V-hook to the lamp.

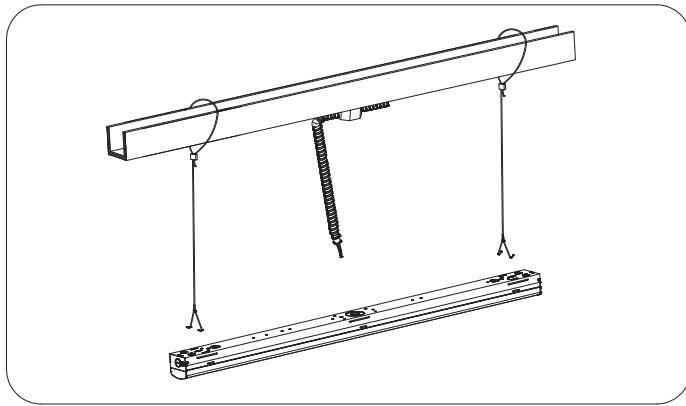

4. Connect the AC wires.

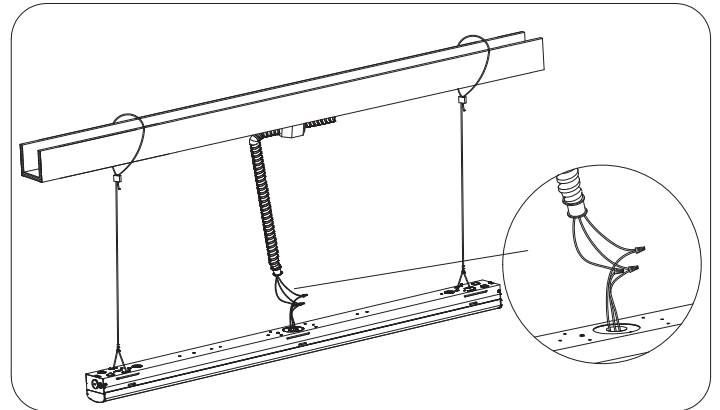

5. The installation is completed.

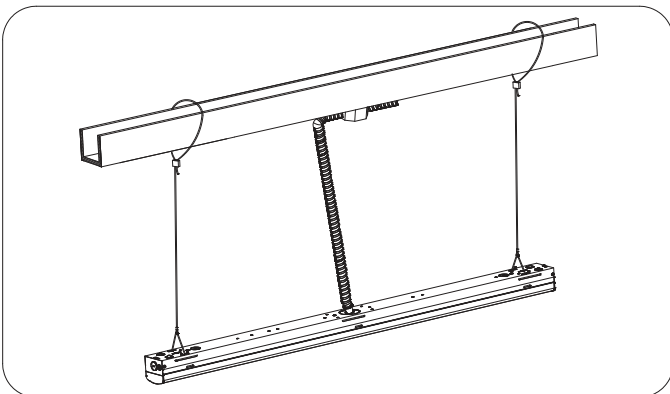

Installation Instruction

Additional Accessories

- Emergency Battery Back-up

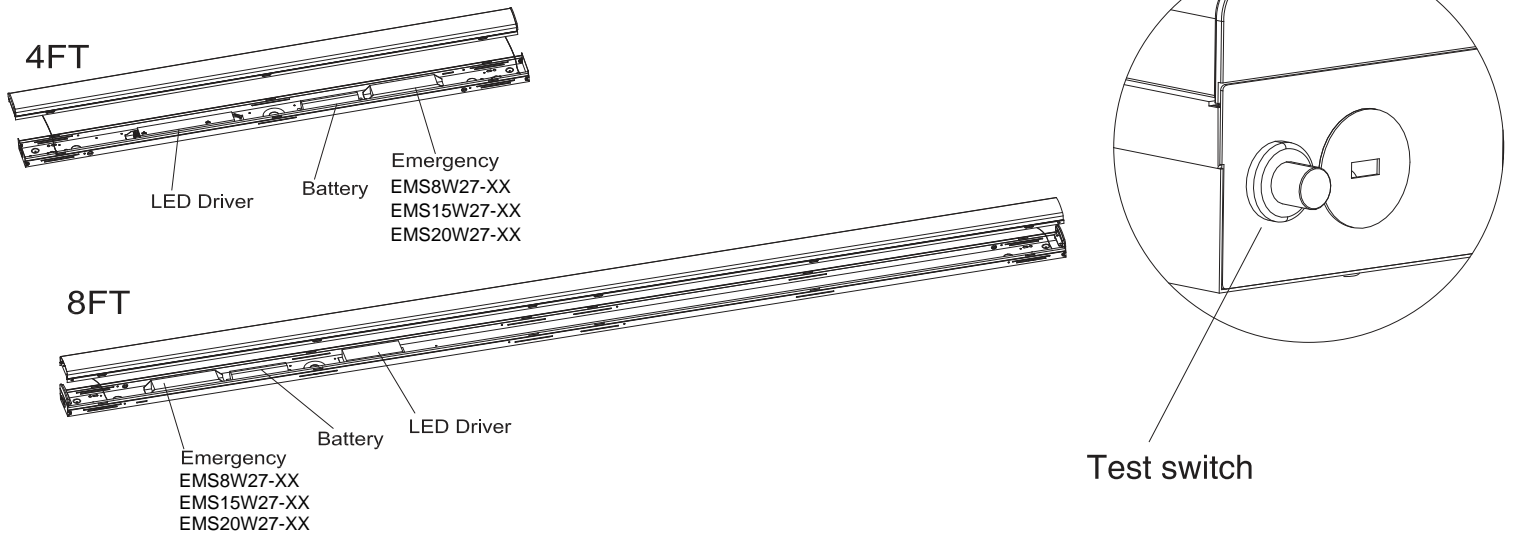

General Wiring Diagram

if emergency color temperature
is 3500K and 4000K

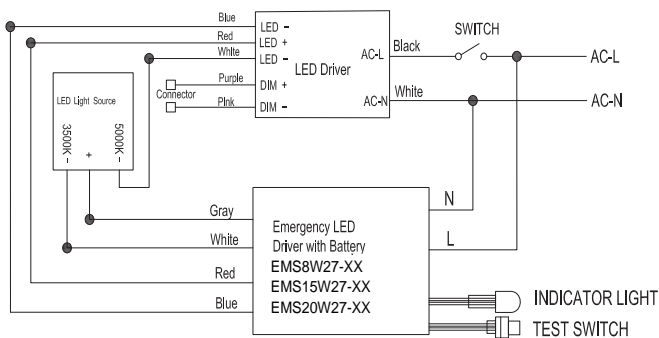

if emergency color temperature
is 4000K and 5000K

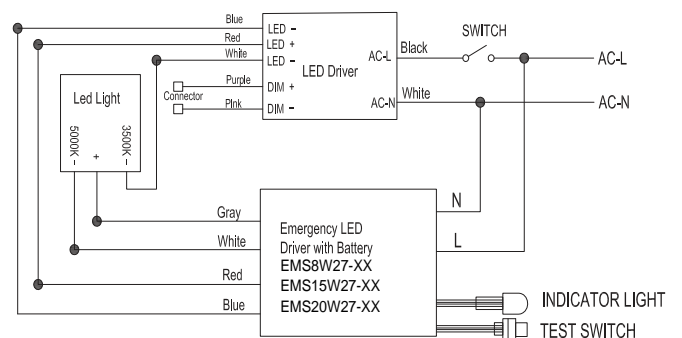

Installation Instruction

Field-Adjustable Wattage & CCT

2FT&4FT

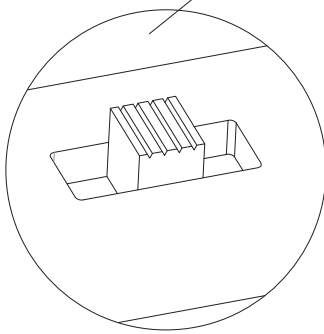
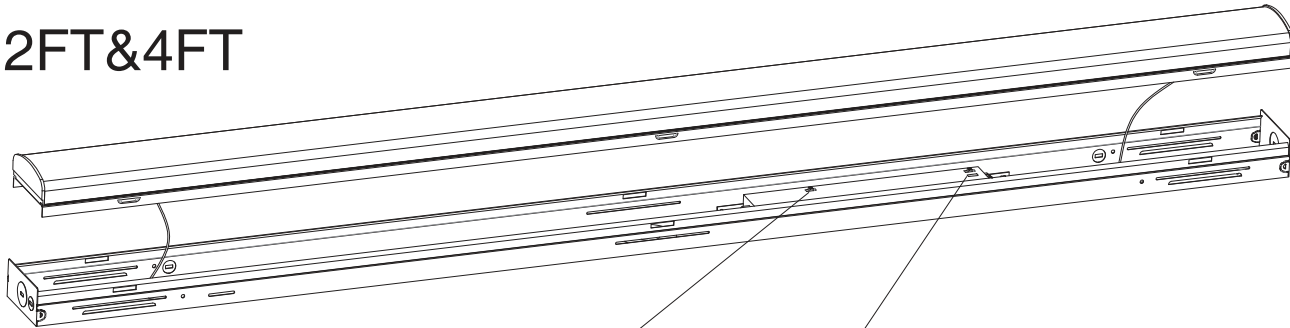

Wattage Switch

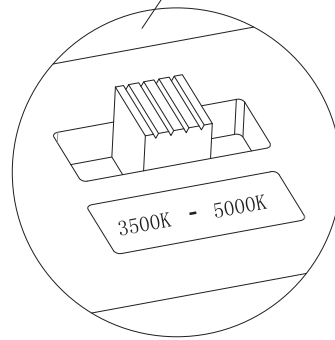

CCT Switch

The end users may adjust the color temperature and lumen output respectively by the two DIP switch. Each DIP switch is accommodated with 3 options (left, middle and right), corresponding to 3 color temperatures and 3 powers respectively, which can perform the desired color temperature and lumen output combination.

1. DIP switches are located onto the side of the fixture.
2. Select a wattage and color temperature by sliding switch left or right respectively to the desired value.

Installation Instruction

Field-Adjustable Wattage & CCT

8FT

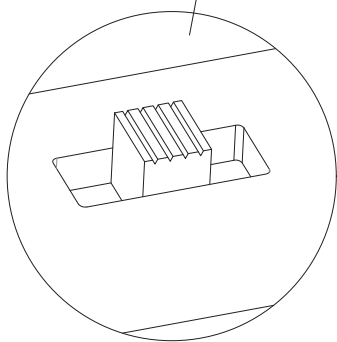
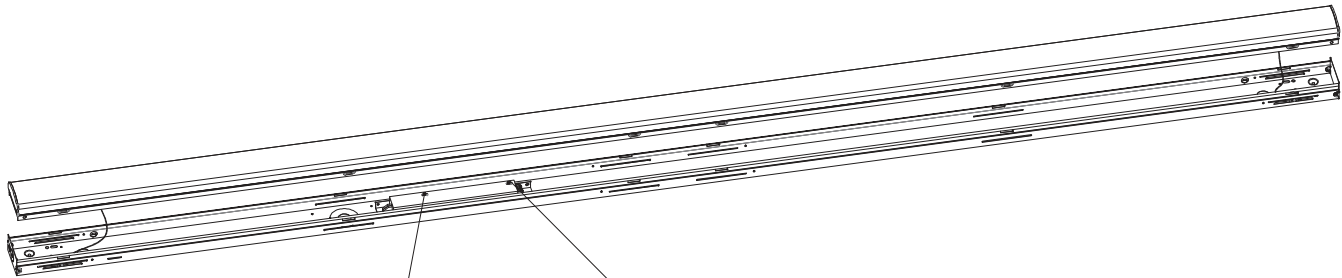

Wattage Switch

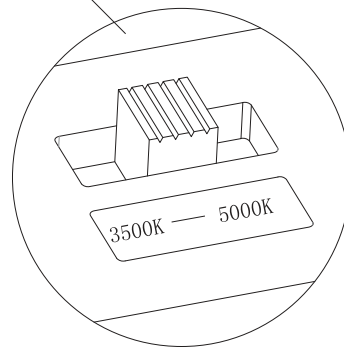

CCT Switch

The end users may adjust the color temperature and lumen output respectively by the two DIP switch. Each DIP switch is accommodated with 3 options (left, middle and right), corresponding to 3 color temperatures and 3 powers respectively, which can perform the desired color temperature and lumen output combination.

1. DIP switches are located onto the side of the fixture.
2. Select a wattage and color temperature by sliding switch left or right respectively to the desired value.

Installation Instruction

Additional Accessories

- Standalone DC Sensor
- ANT-3C

Step 1: Remove the sensor-hole plate before or after you install the fixture. (Figure 1)

Step 2: Connect the dimming wires and 12V AUX wire to the approved sensor. (Figure 2)

Step 3: Install the approved sensor and make sure it is securely fit. (Figure 3)

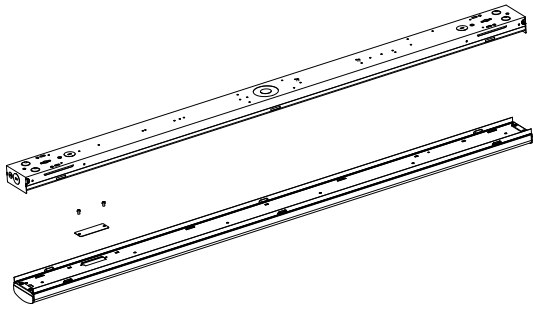

Figure 1

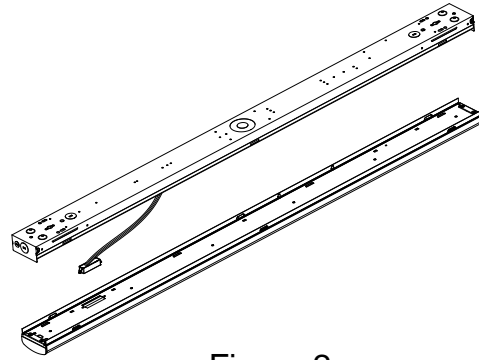

Figure 2

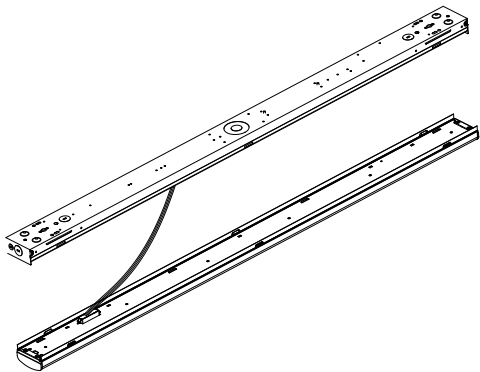

Figure 3

General Wiring Diagram

